



| | | |
|-----------------------------|-----------------------------------|----------------------------------|
| Submittal Data Sheet | CH-60LCDTU/I (INDOOR UNIT) | CH-60LCU/O (OUTDOOR UNIT) |
|-----------------------------|-----------------------------------|----------------------------------|

Job Name: _____
 Location: _____
 Engineer: _____
 Submitted to: _____
 Submitted by: _____
 Reference: _____

Date: _____
 Approval: _____
 Construction: _____
 Unit #: _____
 Drawing #: _____



This warranty should be registered on our web-site www.cooperandhunter.us within 60 days of installation. The warranty is only valid when installed by a Licensed HVAC Technician. A warranty period of Seven (7) years on compressor to the original registered end-user. A warranty period of Five (5) years on all parts to the original registered end user. Warranty applies only to products remaining in their original installation location.

GENERAL FEATURES

- Flexible Installation
- Fresh Air Function
- Wired Control & Wi-Fi Connection
- Multi-Channel Air Distribution
- Built-In Water Pump
- Golden fin for outdoor and indoor
- Lower Noise
- Higher Pipe Limits
- Slim Design

INDOOR SPECIFICATION

| | |
|---------------------------------|----------------|
| Sound Pressure level (Hi/Mi/Lo) | 57/54/51 dB(A) |
| Design pressure | 550/340 PSIG |
| Dimension (W*D*H) | 55x34x17 in |
| Net/Gross weight | 163/189.6 Lb |

OUTDOOR SPECIFICATION

| | | |
|-------------------------------|----------|-------------------|
| Air flow | CFM | 4414 |
| Noise level | dB(A) | 64.0 |
| Dimension (W*D*H) | in | 37.48x16.34x52.48 |
| Net/Gross weight | Lbs | 224.9/254.4 |
| Refrigeran Type | R410/163 | |
| Refrigerant precharge | ft | 25 |
| Additional charge for each ft | oz | 0.32 |

| PERFORMANCE AND EFFICIENCY | Cooling | | |
|----------------------------|----------------|-------|-------|
| | Capacity | Btu/h | 57000 |
| | SEER | | 18.0 |
| | EER | Btu | 10.0 |
| | Input | W | 5700 |
| | Heating at 47F | | |
| | Capacity | Btu/h | 62000 |
| | COP | W/W | 3.6 |
| | HSPF4 | | 9.0 |
| | HSPF5 | | 7.6 |

OPERATION TEMPERATURE RANGE

| Indoor | | Outdoor | |
|----------|----------|----------|---------|
| cooling | heating | cooling | heating |
| 62~90 °F | 32~86 °F | 5~122 °F | 5~86 °F |

ELECTRICAL

| Power supply | V/Hz/Ph | 208-230V/ 60Hz/ 1Ph |
|-------------------|---------|---------------------|
| MCA | A | 36 |
| MFA | A | 50 |
| Indoor fan motor | | |
| Input | W | 420 |
| RLA | A | 3.65 |
| Outdoor fan motor | | |
| Input | W | 126 |
| RLA | A | 1.2 |
| Compressor | | |
| Capacity | Btu/h | 44697 |
| Input | W | 3420 |
| RLA | A | 23.5 |

MCA: Minimum Circuit Ampacity; **MFA:** Max.fuse amps; **RLA:** Rated load amps

PIPING

| | | |
|-----------------------------|----|------------|
| Refrigerant piping/Gas side | in | (3/8"3/4") |
| Max. pipe length | ft | 213 |
| Max. difference in level | ft | 98 |

Duct Light Commercial Series

Duct Air Conditioners



CH-60LCDTU/I (INDOOR UNIT)

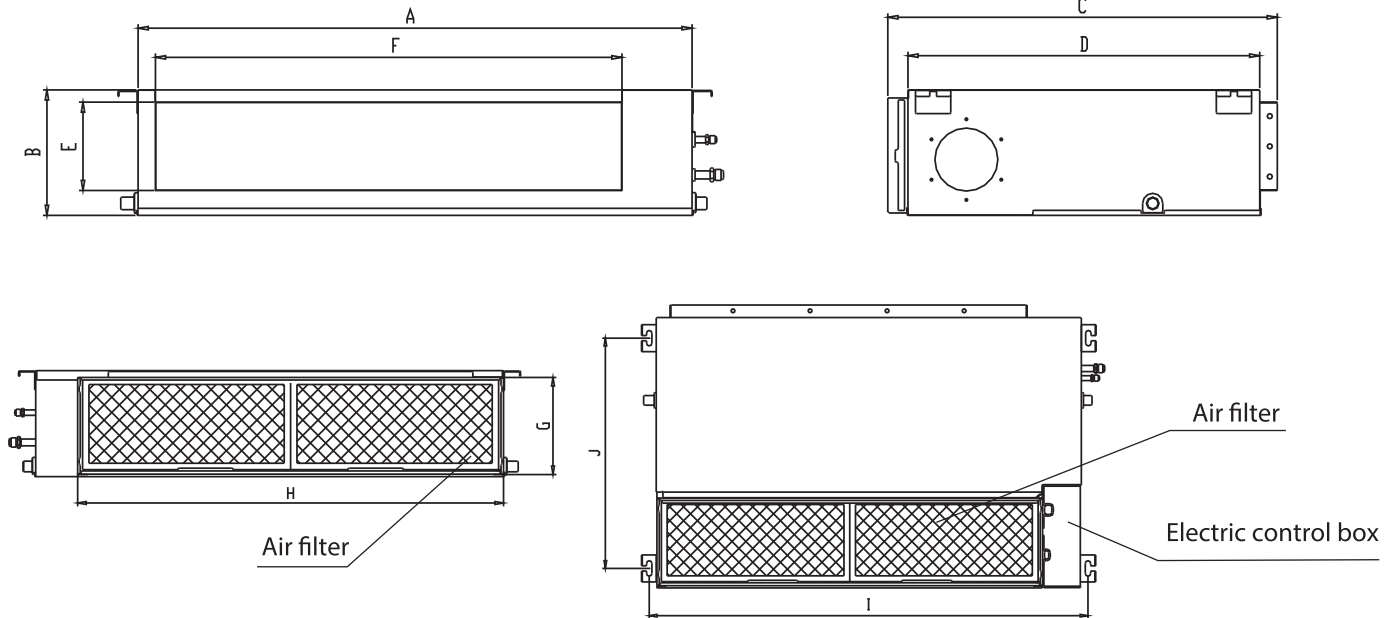

| MODEL (Btu/h) | Outline dimension | | | | air outlet opening size | | air return opening size | | Size of mounted lug | |
|------------------|-------------------|----|----|------|-------------------------|------|-------------------------|------|---------------------|-------|
| | A | B | C | D | E | F | G | H | I | J |
| 60K | 55 | 17 | 34 | 31.5 | 8.9 | 41.1 | 11 | 43.3 | 48.8 | 43217 |

CH-60LCU/O (OUTDOOR UNIT)

